



# VACUUM PACKING MACHINE SU-806GP CC 230-400/50/3N

Floorstanding unit. 63 m<sup>3</sup>/h. 581+581 mm.



P/N 1140891



## INCLUDES

- ✓ Filling plate
- ✓ Inert gas flush
- ✓ Bluetooth connectivity
- ✓ Printer connection

## ACCESSORIES

- Bag cutting kits
- Filling plates
- Liquid insert plates
- Vac-norm external vacuum kits
- Vac-norm containers
- Smooth bags for vacuum packing
- Thermal labels for CG2 / RB printer
- RB Desktop printer for SU vacuum packing machines
- Thermal transfer labels for RB printer

## SALES DESCRIPTION

Two sealing bars (581+581 mm.)  
 63 m<sup>3</sup>/h Busch vacuum pump.  
 Vacuum controlled by sensor.

- ✓ Powered by Busch.
- ✓ Vacuum controlled by sensor.
- ✓ Vacuum PLUS.
- ✓ LCD colour screen: all information at a glance.
- ✓ Backlit touch keyboard.
- ✓ Programmable: 25-programme memory. Blocking option.
- ✓ "Pause" button.
- ✓ Phased vacuum programme.
- ✓ Detection of the evaporation of liquids.
- ✓ Double seal.
- ✓ Cordless sealing bar.
- ✓ Progressive decompression.
- ✓ Vac-Norm ready with Automatic decompression.
- ✓ Stainless steel body and chamber.
- ✓ Damped transparent lid of high durability polycarbonate.
- ✓ Dry-oil programme for drying the pump.
- ✓ Working hours counter for oil changes.
- ✓ Safety system with protection against vacuum failure.
- ✓ NSF-listed.



**sammic** | [www.sammic.com](http://www.sammic.com)  
**Food Service Equipment Manufacturer**

Polígono Basarte, 1. phone +34 943 15 72 36  
 20720 Azkoitia, Spain [sales@sammic.com](mailto:sales@sammic.com)



Project	Date
Item	Qty
Approved	

FOOD PRESERVATION AND SOUS-VIDE  
 VACUUM PACKING MACHINES - "SENSOR ULTRA" LINE

product sheet  
 updated 10/09/2021



# VACUUM PACKING MACHINE SU-806GP CC 230-400/50/3N

Floorstanding unit. 63 m<sup>3</sup>/h. 581+581 mm.



P/N 1140891

## SPECIFICATIONS

Pump capacity: 63 m<sup>3</sup>/h  
Bar length: 581 mm + 581 mm  
Total loading: 1500 W  
Vacuum pressure (maximum): 0.5 mbar  
Electrical supply: 400 V-[v:002\_tension2] / 50 Hz / 3N ~ (6.7 A)

### Internal dimensions

- ✓ Width: 864 mm
- ✓ Depth: 603 mm
- ✓ Height: 215 mm

### External dimensions (WxDxH)

- ✓ Width: 960 mm
- ✓ Depth: 757 mm
- ✓ Height: 998 mm

Net weight: 232 Kg  
Noise level (1m.): 75 dB(A)  
Background noise: 32 dB(A)

### Crated dimensions

840 x 1060 x 1200 mm  
Gross weight: 257 Kg.

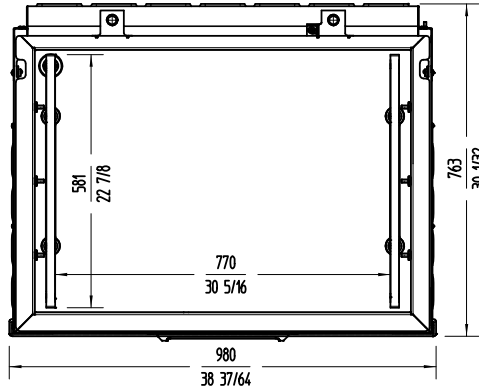
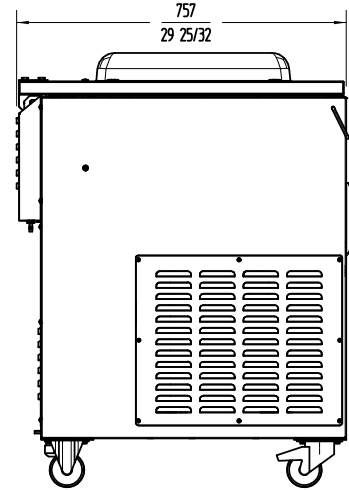
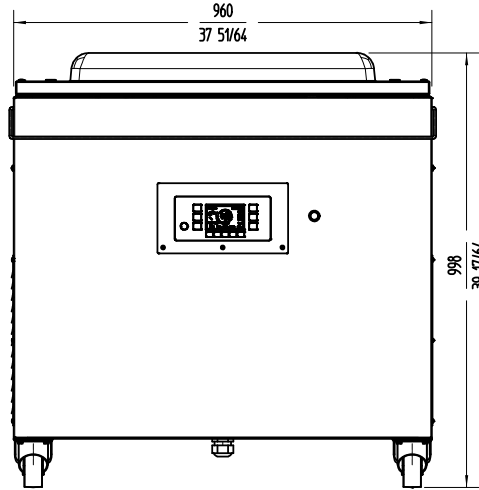

FOOD PRESERVATION AND SOUS-VIDE  
VACUUM PACKING MACHINES - "SENSOR ULTRA" LINE

**sammic** | www.sammic.com  
Food Service Equipment Manufacturer

Polígono Basarte, 1. phone +34 943 15 72 36  
20720 Azkoitia, Spain sales@sammic.com



Project	Date
Item	Qty
Approved	

product sheet  
updated 10/09/2021